



➤ B-548 POST-MOUNTED MESSAGE SIGN

Ver-Mac's B-548 is a small full-matrix post-mounted (permanent) message sign. It features the NTCIP-compliant V-Touch controller and JamLogic® fleet management software. The B-548 can display graphics and 3 lines with 9 characters (9 in.) per line. Our B-548 can be powered either with an AC system, an AC system with battery backup or with a DC system. It can be designed with Z-Bars or with clampings, depending on the structure that the sign will be mounted on. Our B-548 is perfect to use on the side of urban roads or in city downtown where space is limited.



V-TOUCH CONTROLLER

NTCIP COMPLIANT

EASY-TO-READ

7-inch (178 mm) color LCD touchscreen display

USER-FRIENDLY

One-click icon-based menu items

TIME-SAVING

Create your own library of messages

SIMPLE TO OPERATE

The intuitive point-n-go icons ensure quick and easy commands to display or edit messages

ADDITIONAL FUNCTIONALITIES

Scheduling, sign diagnostics, pin-protected security, and much more





JAMLOGIC FLEET MANAGEMENT SOFTWARE

Ver-Mac's B-548 comes with our high-speed modem with GPS to maximize your productivity, efficiency and profitability all remotely from your office or home!

- Monitor, maintain and manage your signs from any PC, laptop, tablet or smartphone
- View your equipment in a list and GPS map view
- Change a message on one or more signs simultaneously with a simple click
- View your messages and battery voltages
- Group your signs in folders (by customer, location, project... you choose!)
- Receive e-mail or text alerts – optional (low battery cellular failure, etc.)

DISPLAY

- Display panel: 45 x 80 in. (1146 x 2027 mm)
- Full matrix of 30 x 56 pixels
- 2 LED per pixel
- 3 lines of 9 characters per line (5 x 7 default font)
- Up to 3 lines of 13 characters per line (3 x 7 font)
- 9 in. (229 mm) characters (default)
- Plug-and-play display modules for simplified maintenance

POWER SUPPLY OPTIONS

- AC System (direct current as primary source)
- AC System with battery backup
- DC System (Solar & battery powered)

WARRANTY

- 1 year on complete sign
- 2 years on electronic components manufactured by Ver-Mac

MOUNTING OPTIONS

Z-Bar mounting for bridge, gantry
i-beam posts structures

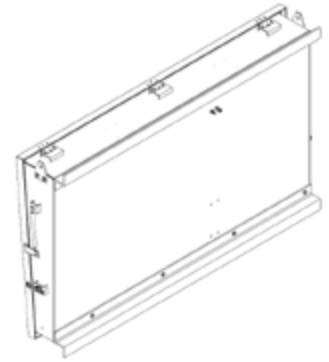

Clamping mounting for round post
installation (various sizes available)

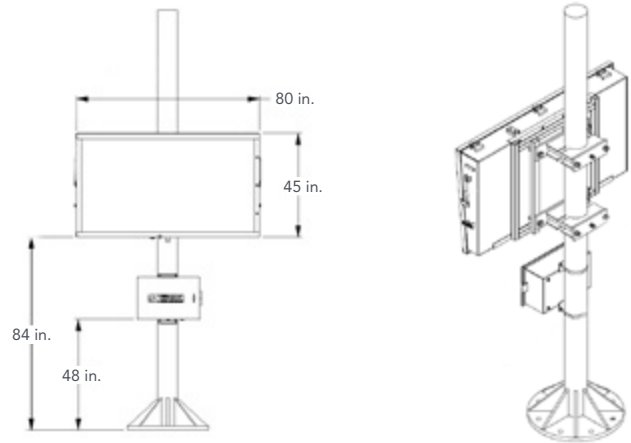

*Post for representation only (not included)

*Other custom mounting options are available on request

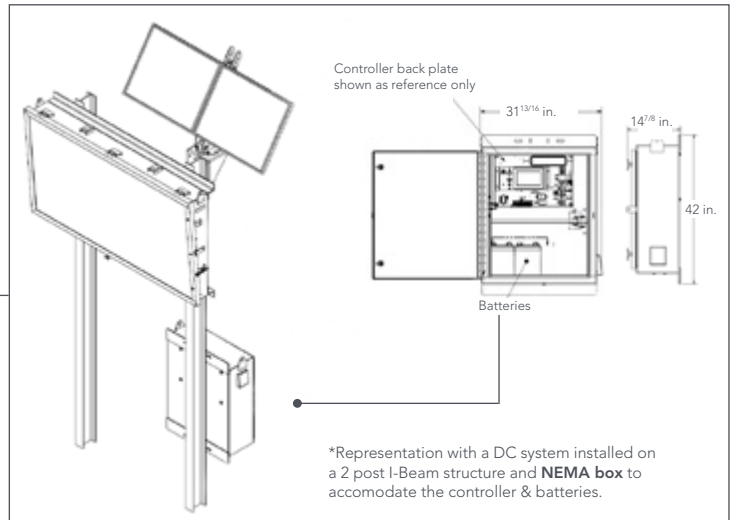

*Representation with a DC system installed on a 2 post I-Beam structure and NEMA box to accommodate the controller & batteries.

